

Utility Counters Models J710 & J710A

Aladdin Temp-Rite's utility counters are designed to round out tray assembly with a versatile multipurpose work service which provides an efficient work station.

Standard counters include under storage to optimize storage space and are available in two lengths.

Standard Features:

- **Cabinet Construction:** Durable, 14-gauge stainless steel counter top 37" (94 cm) height above the floor. Counter top edges features a #7 Hi-Lite finish. Stainless steel front and end panels. Heavy gauge all-metal construction with reinforcement at stress points.
- **Under-Storage:** Standard model includes open under-storage with intermediate shelf and stainless steel floor panels to provide additional storage space.
- **Casters:** Four 5" (12.7 cm) swivel non-marking casters with brakes.

Ease of Use:

- Lower shelf for extra storage space
- No assembly required
- Removable floor panels

Customization:

Are you interested in custom utility counters? Contact your Aladdin Territory Manager for additional information.



Model J710 shown



NOTE: Available Options Must Be Specified When Ordering

Available Options	Important Specification Information
<input type="checkbox"/> Single-tier, stainless steel over-shelf ¹	14.25" (36.2 cm) height increase
<input type="checkbox"/> Double-tier, stainless steel over-shelf ¹	27" (68.6 cm) height increase
<input type="checkbox"/> Convenience outlet to plug in additional tray assembly equipment ²	Standard outlet is NEMA 6-20P, 208v/20A, straight-blade receptacle located at center of back splash (operator's side). Alternate location of receptacle or electrical requirements must be specified at the time of order.
<input type="checkbox"/> Vinyl Color Options	

¹ Overall dimensions and weight may change with the addition of options. Refer to option table for additional detail.
² Addition of convenience outlet will add electrical requirements utility counter

Utility Counters

Models J710 & J710A

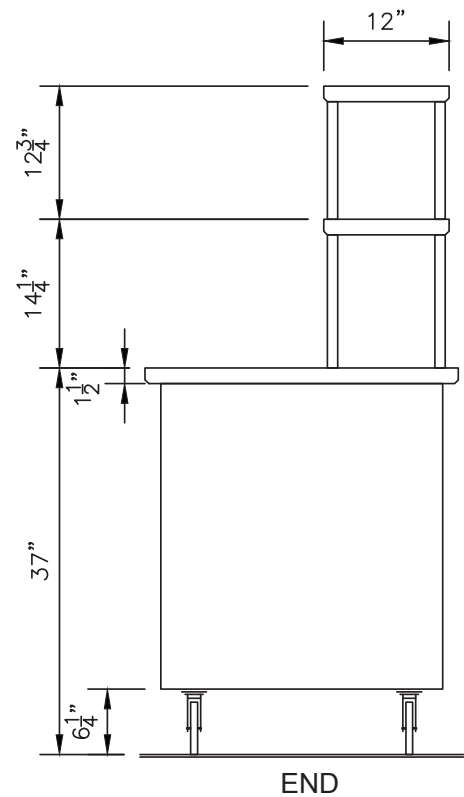
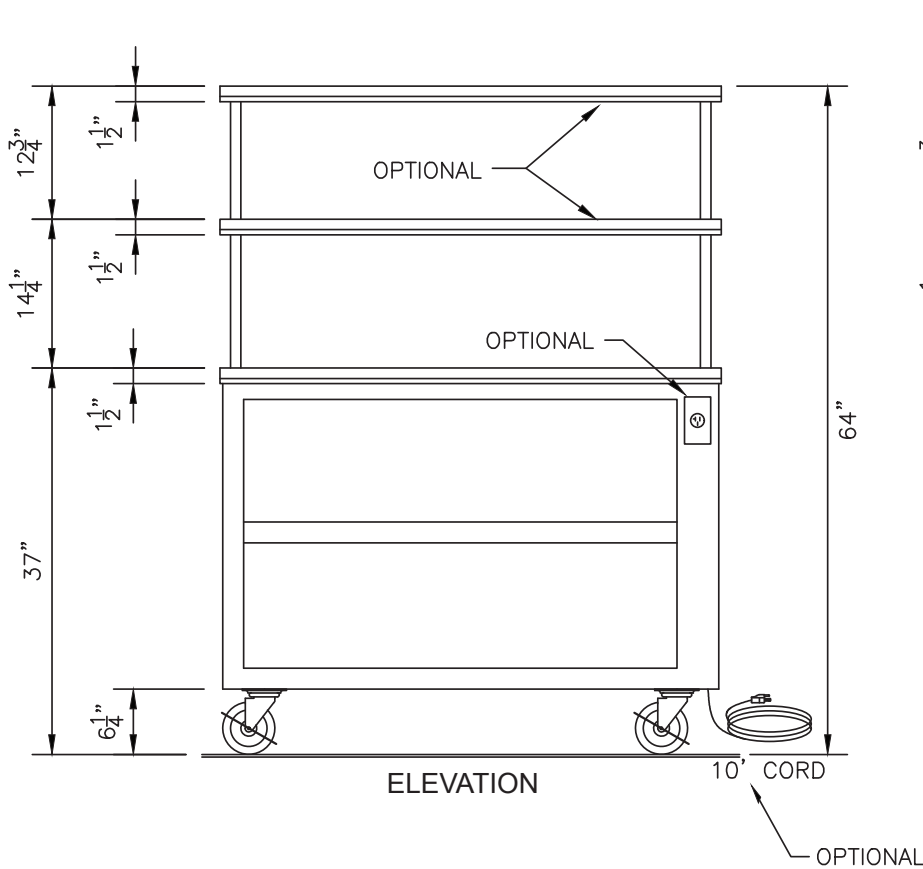
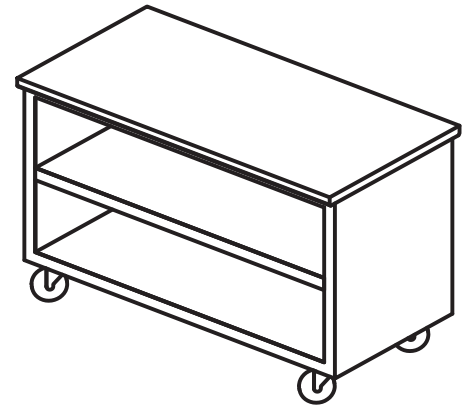
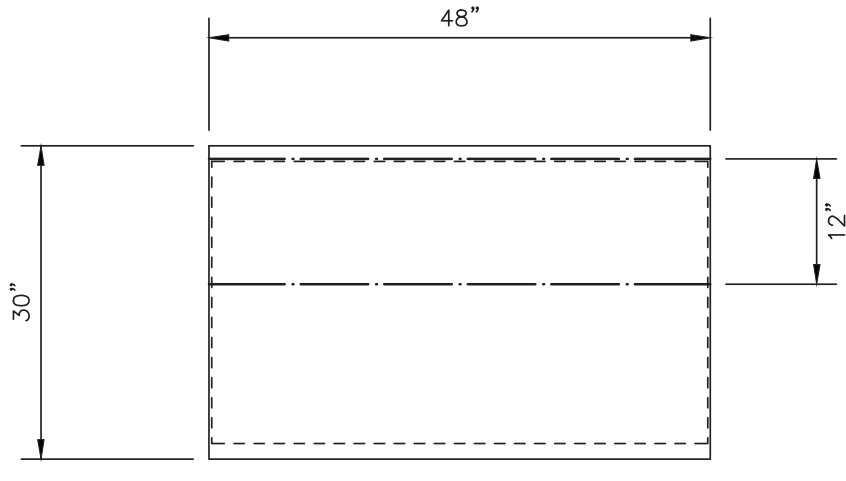

Base Model Number	Description	Length	Width	Total Height	Shipping Weight (lbs.)
<input type="checkbox"/> J710	4' counter	48" (121.9 cm)	30" (76.2 cm)	37" (94 cm)	300 lbs (136 kg)
<input type="checkbox"/> J710A	5' counter	60" (152.4 cm)	30" (76.2 cm)	37" (94 cm)	380 lbs (172 kg)

Visit aladdintemprite.com/patents for patent information.

250 E. Main St. | Hendersonville, TN 37075 | Customer Service: 800.888.8018 | Tech Service: 800.888.5426 | Fax: 888.812.9956 | aladdintemprite.com

©2021 Aladdin Temp-Rite®. All rights reserved. Note: Specifications are subject to change without notice.



Rev. B 5211216J710

an Ali Group Company



The Spirit of Excellence